

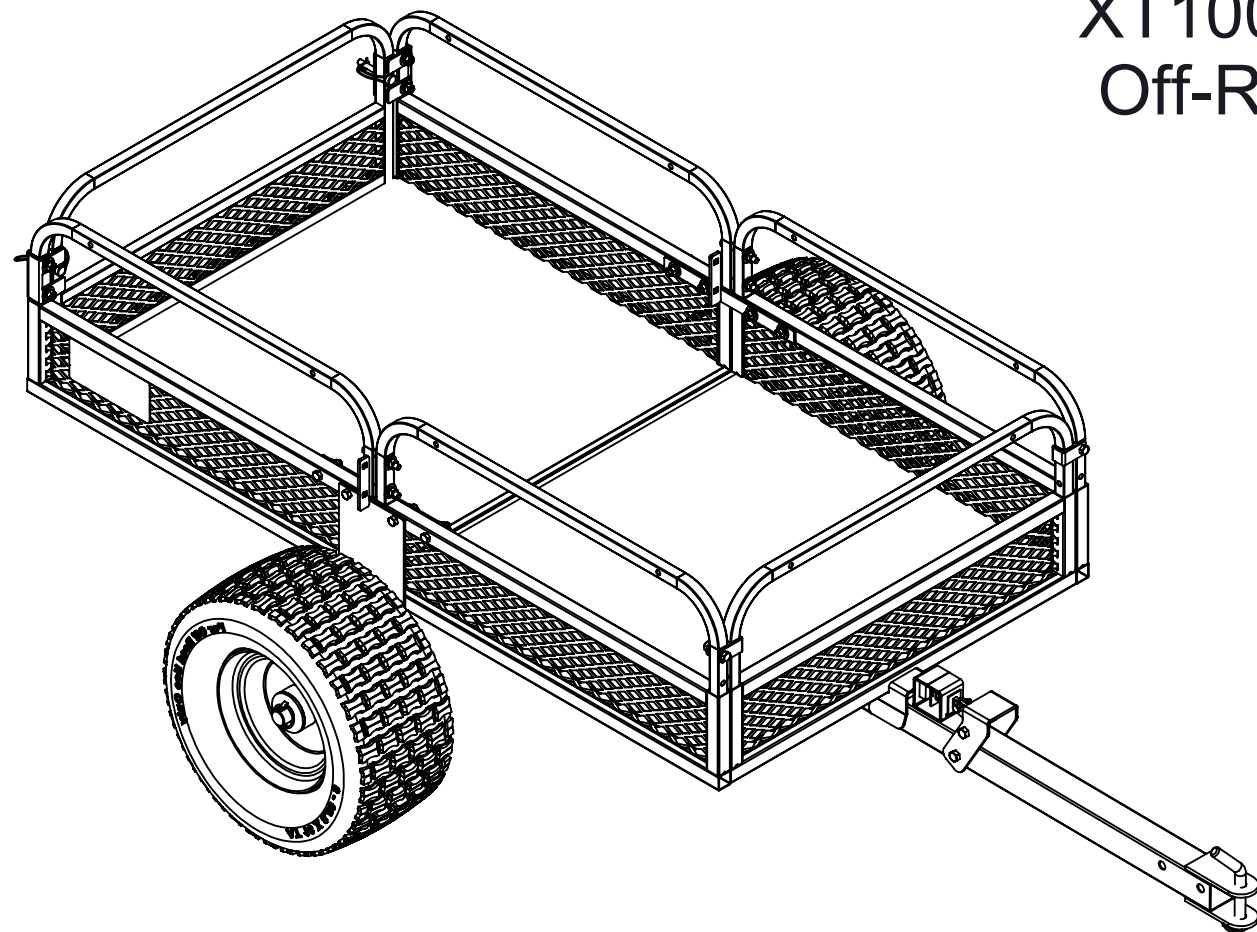

Assembly Instructions:
Impact Implements
XT1000 & XT1500
Off-Road Trailers

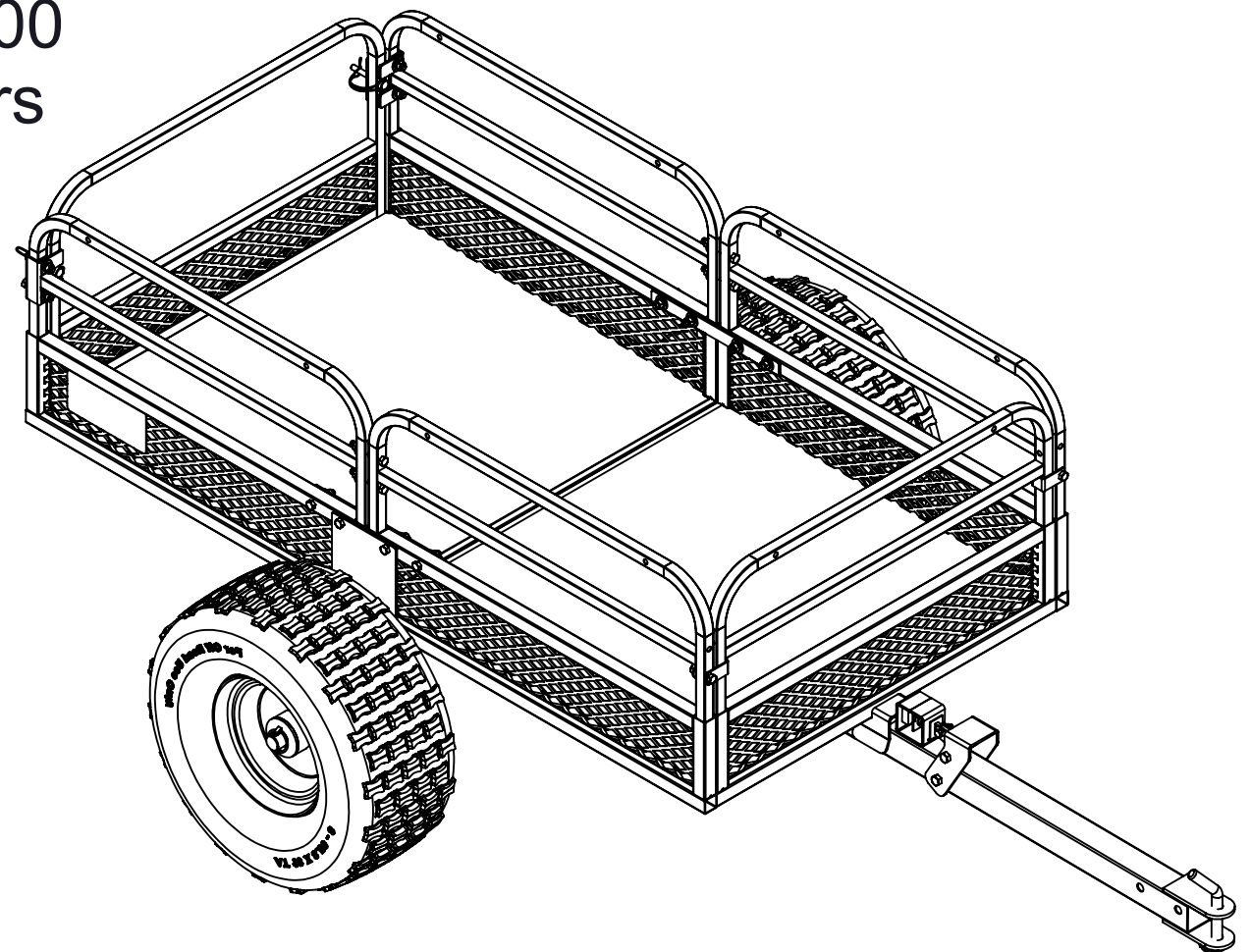

Item #2094
XT1000 Off-Road Trailer
Rated Capacity 1000lb



Item #2100
XT1500 Off-Road Trailer
Rated Capacity 1500lb



Important! Please Read First

READ, UNDERSTAND AND FOLLOW ALL ASSEMBLY INSTRUCTIONS PROVIDED BEFORE EACH USE. FAILURE TO FOLLOW ALL WARNINGS AND INSTRUCTIONS COULD RESULT IN SERIOUS INJURY OR DEATH.

DOUBLE CHECK THE ASSEMBLY OF YOUR TRAILER TO BE SURE YOU ASSEMBLED IT CORRECTLY AND ALL NUT & BOLT ASSEMBLIES ARE TIGHT BEFORE INITIAL USE. BE SURE TO PERIODICALLY CHECK ALL NUT AND BOLTS FOR TIGHTNESS. OVER TIME, NUTS AND BOLTS MAY BECOME LOOSE FROM VIBRATION.

BE SURE TO ALWAYS HAVE THE CORRECT AMOUNT OF AIR PRESSURE IN TIRES. THIS WILL HELP DETER FROM UNNECESSARY WEAR AND/OR DAMAGE. AIR PRESSURE REQUIREMENTS CAN BE LOCATED ON SIDEWALL OF TIRE.

NEVER DRIVE ON HILLY TERRAIN - EXCESSIVE WEIGHT CAN CAUSE WEIGHT SHIFTS WHICH CAN LEAD TO LOSS OF CONTROL OF YOUR ATV AND/OR ATV TRAILER.

DO NOT DRIVE IN-EXCESS OF 10 MPH WHILE USING THIS PRODUCT.

- * **NEVER ALLOW PEOPLE OR ANIMALS TO RIDE IN THE ATV TRAILER!**
- * **THIS TRAILER IS NOT DESIGNED FOR THAT MATTER.**
- * **USE CAUTION NEAR TRAILER TILT LATCH.**
- * **BE SURE LATCH IS ENGAGED BEFORE EACH USE.**

NEVER EXCEED THE MAXIMUM WEIGHT CAPACITY OF THE SPECIFIC TRAILER CAPACITY PURCHASED, ALWAYS EVENLY DISTRIBUTED WEIGHT.

Warning!

This is a low speed, OFF-ROAD trailer and is not intended for road use. Do not tow trailer in excess of 10mph. Inspect trailer for damage before each use. Keep tires inflated to proper tire pressure. Serious injury or death could result from riding in a moving trailer. Always make sure trailer is properly and securely attached to tow vehicle before operating. Never load cargo that exceeds the hauling capacity of trailer. Never haul cargo that exceeds the braking capacity of tow vehicle. Never drive on hilly or uneven terrain as trailer load may shift causing loss of tow vehicle control. When using coupler, be sure coupler load capacity is the same or less than ball load capacity. Make sure hitch and trailer ball are the same size. Use extreme caution when removing rear trailer gate. Never dump trailer while vehicle is moving.

We recommended two people assemble this product.

TOOLS REQUIRED: - Adjustable Wrenches (2), socket set with ratchet & extension, needle nose pliers.

IMPORTANT ASSEMBLY TIP: Do not tighten any nut and bolt combinations completely until all parts are assembled together! Finger tighten plus one turn of a wrench only! This will temporarily hold the nut on the bolt while helping alignment of all parts! After all parts are assembled together, all nut & bolt combinations must be completely tightened.

XT1000 & XT1500 Trailer Instructions



STEP 1 - Verify all hardware is accounted for.

STEP 2 - Verify all loose parts are accounted for.

Trailer Assembly Instructions

Lay out all trailer parts, show detail of all parts

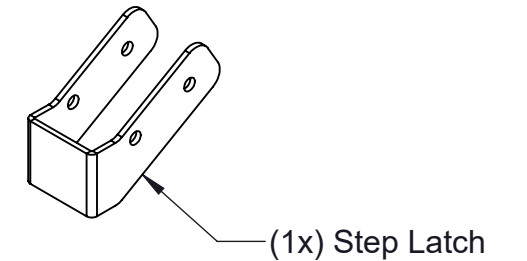
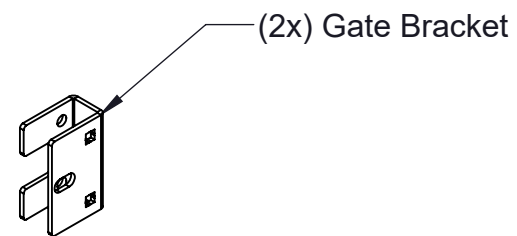
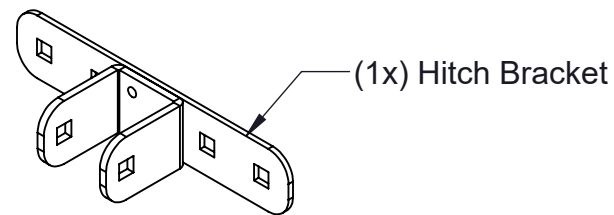
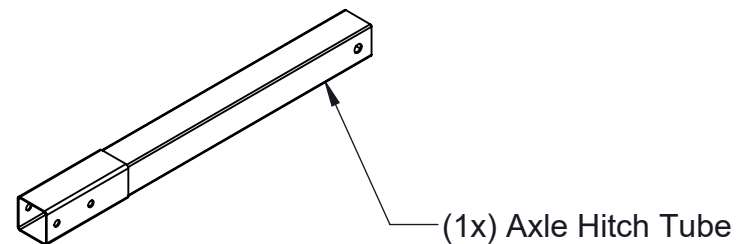
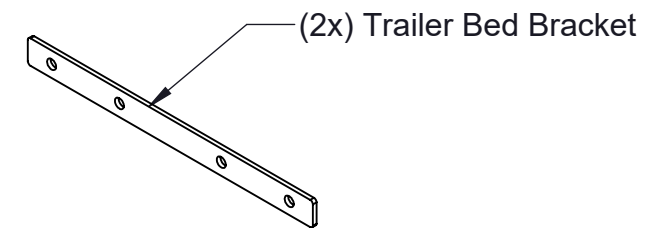
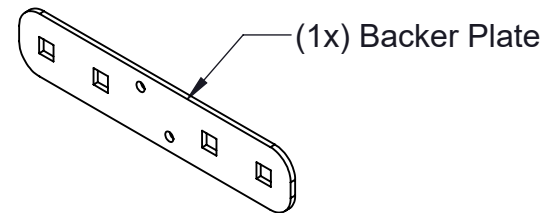
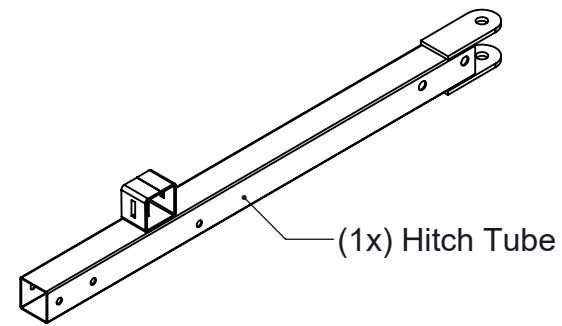
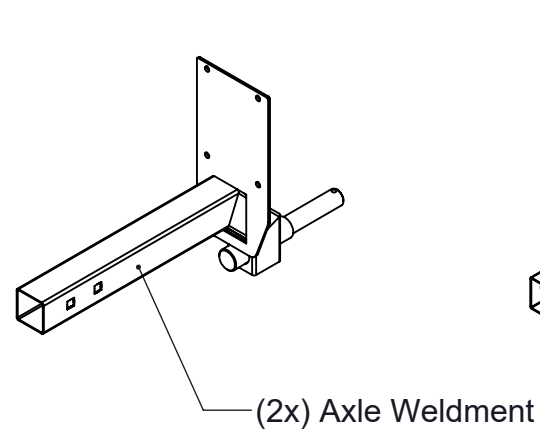
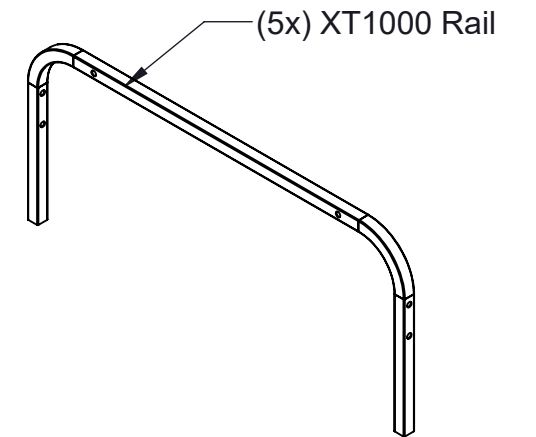
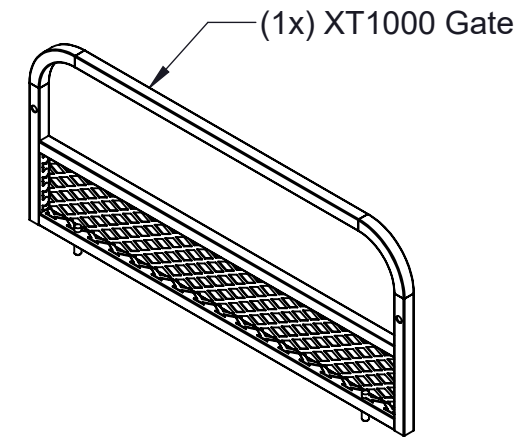
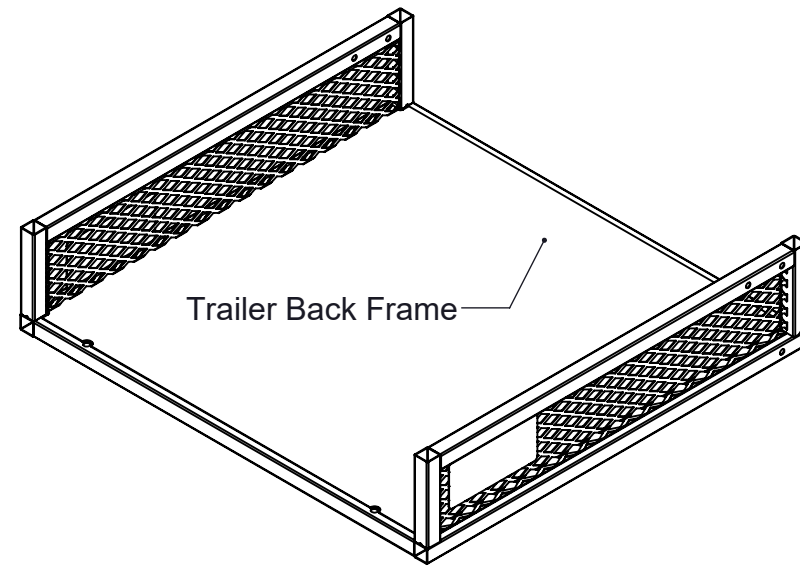
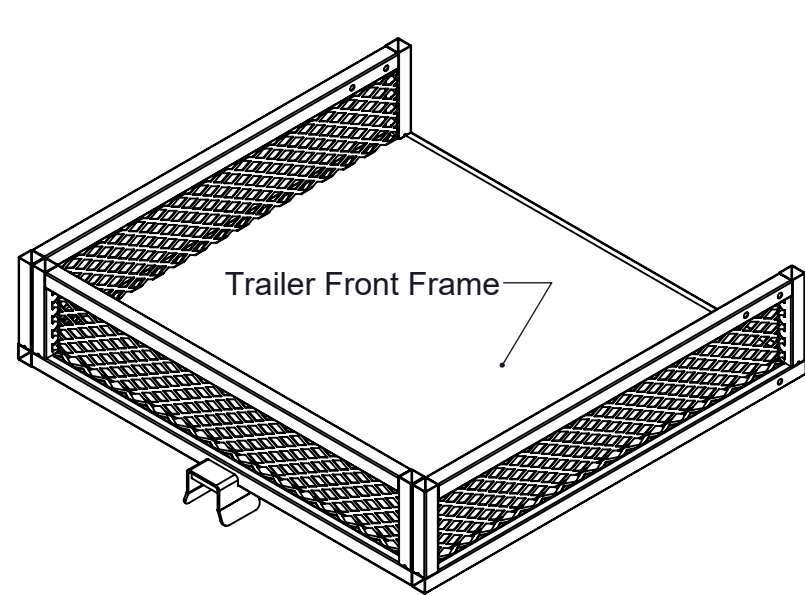
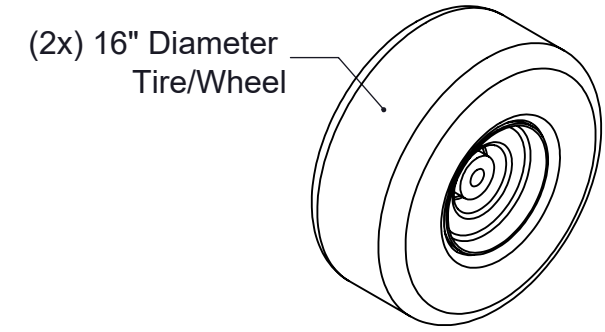

STEP 2 - Verify all loose parts are accounted for.

Trailer Assembly Instructions

Lay out all trailer parts, show detail of all parts

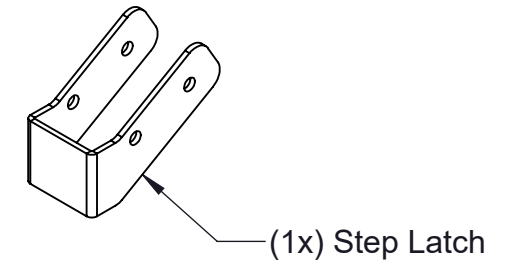
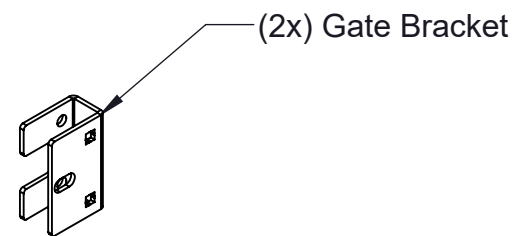
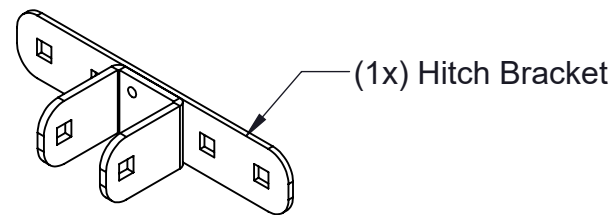
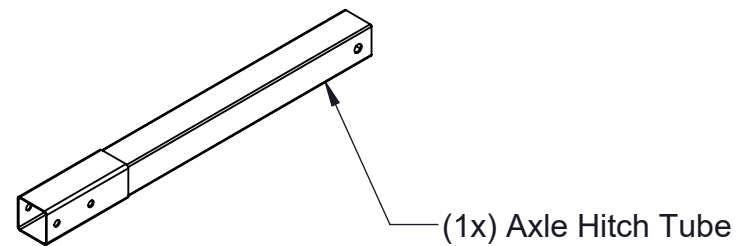
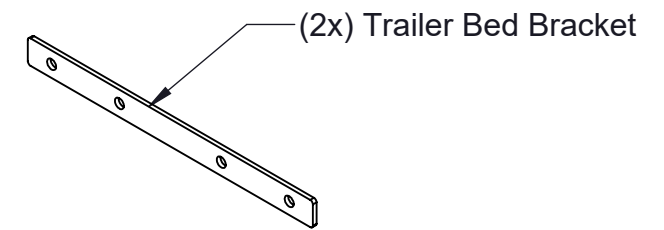
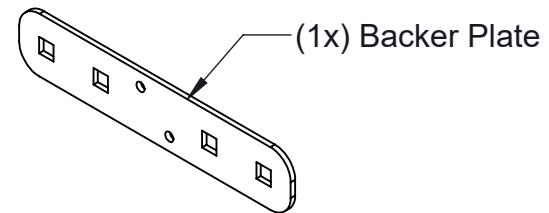
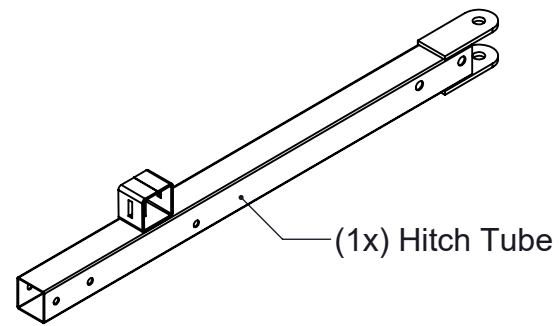
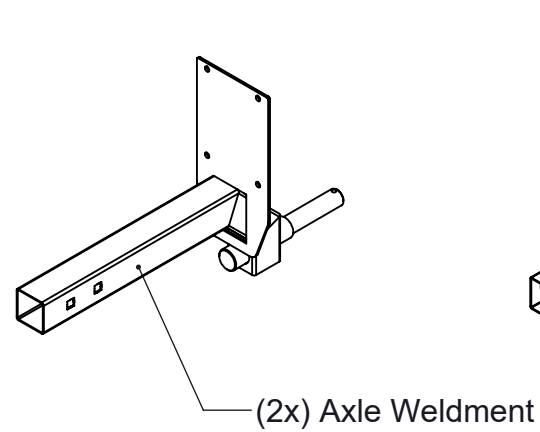
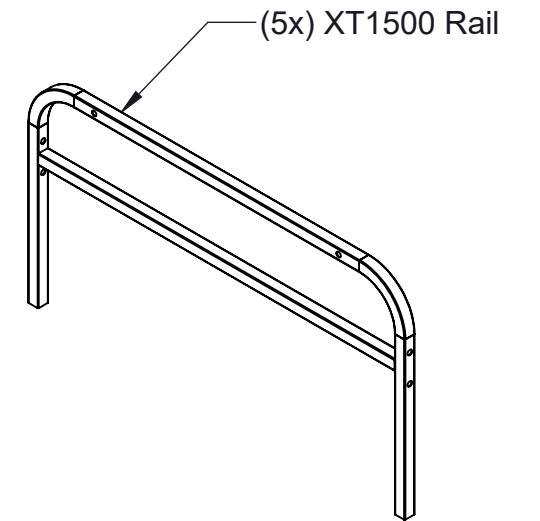
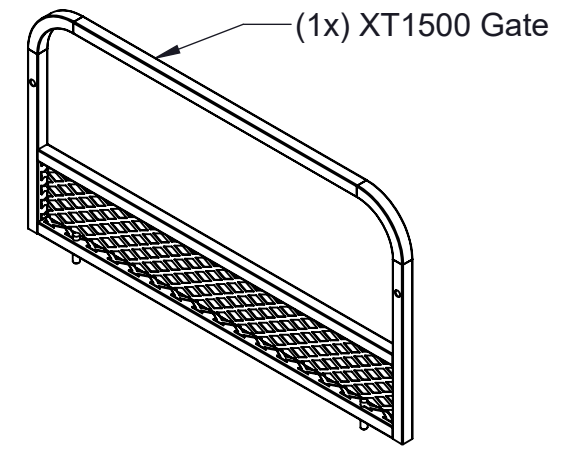
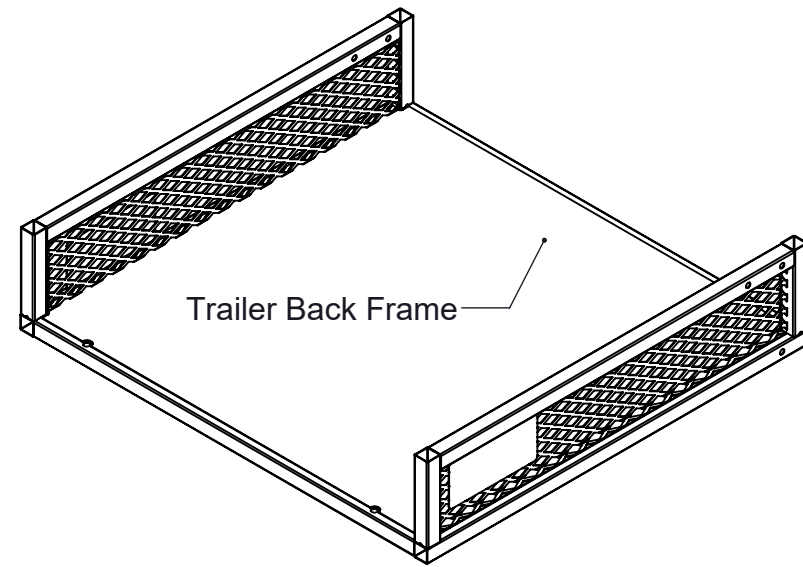
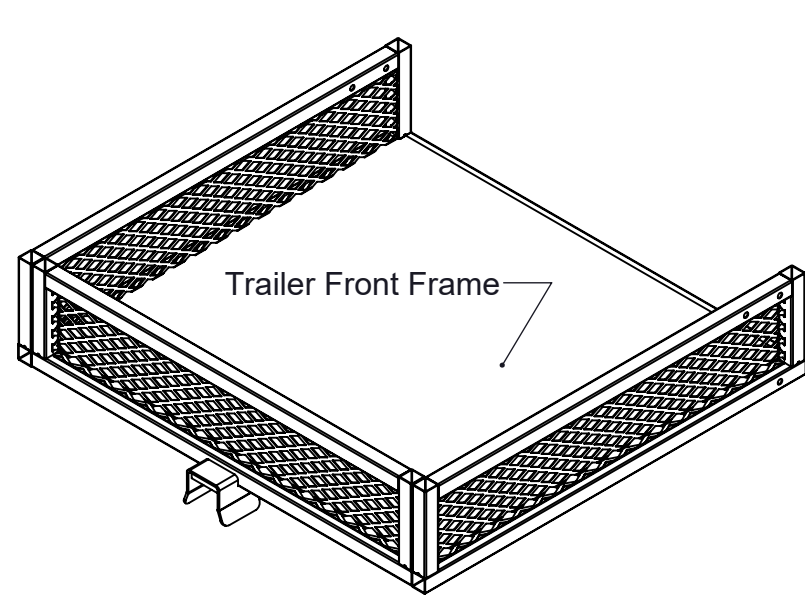
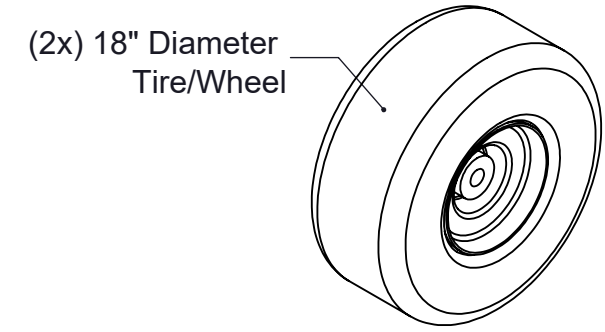

STEP 3

Assembly Notes:

1. Turn front and back trailer bed sections upside down and butt together so four center holes align.
2. Assemble Trailer Frame Hardware
3. Install axle sections with two bolts through each side plate.
4. Install four center axle bolts at Hitch Bracket and Backer Plate.
5. Tighten all hardware at this point.

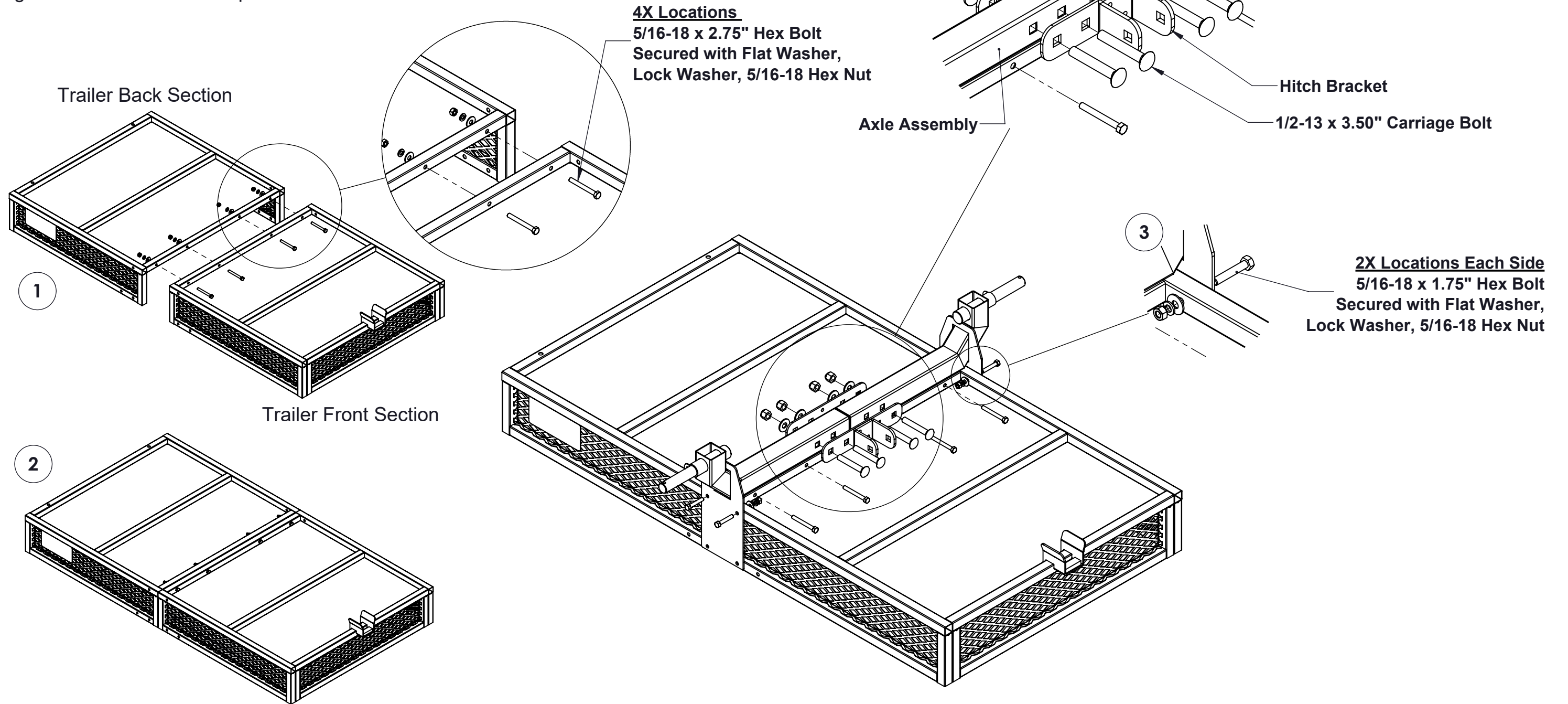

STEP 4

Assembly Notes:

1. Secure upper "Trailer Bed Bracket" with provided hardware shown below.
2. Hand tighten all hardware at this point.
3. Repeat this step for both sides of the trailer bed bracket and hardware.

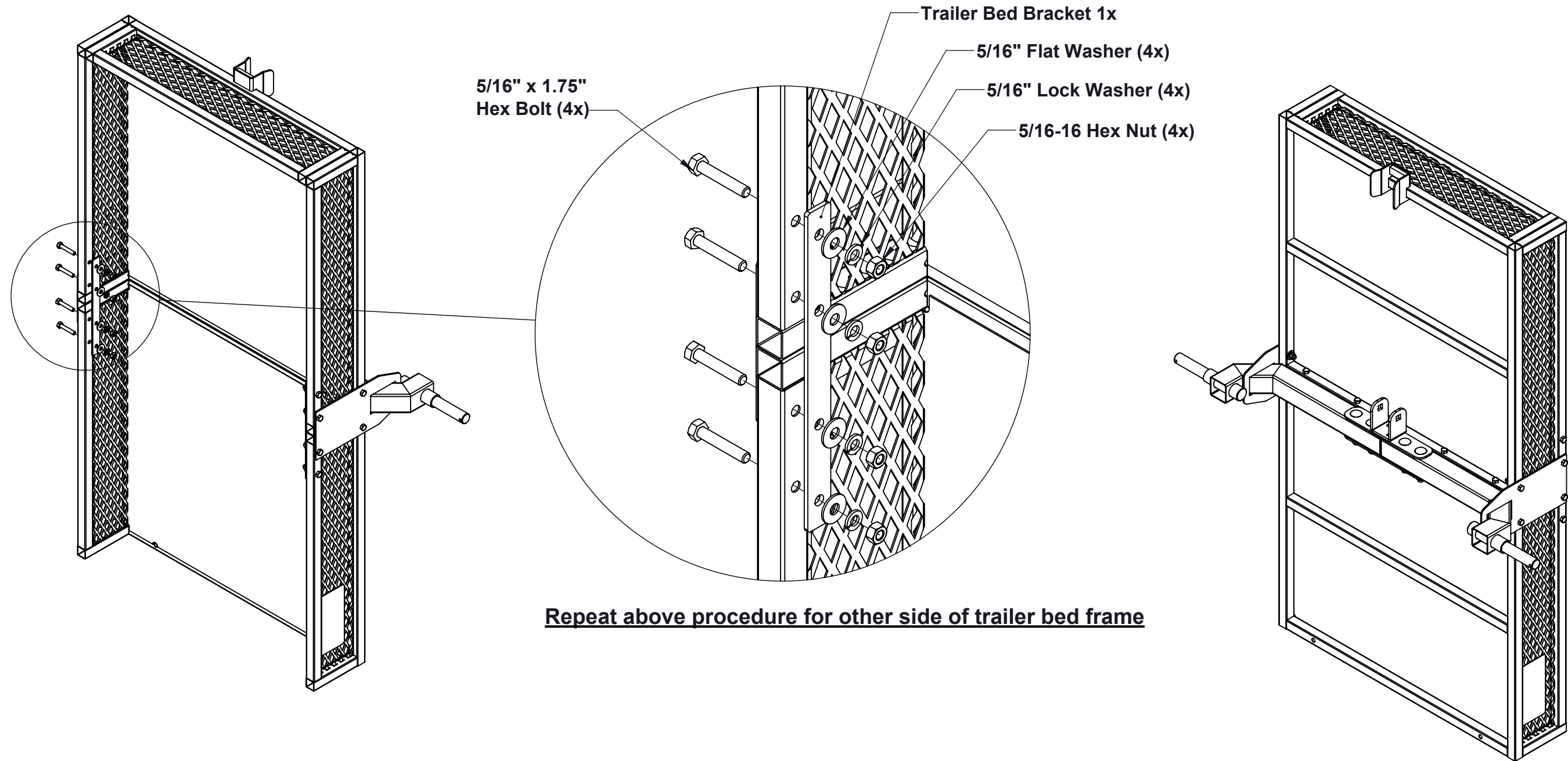

STEP 5

Assembly Notes:

1. Assemble Trip Latch Assembly as shown below.
2. Do not overtighten any of the below shown hardware.
3. Secure hex nuts so that all locations move freely and do not bind.

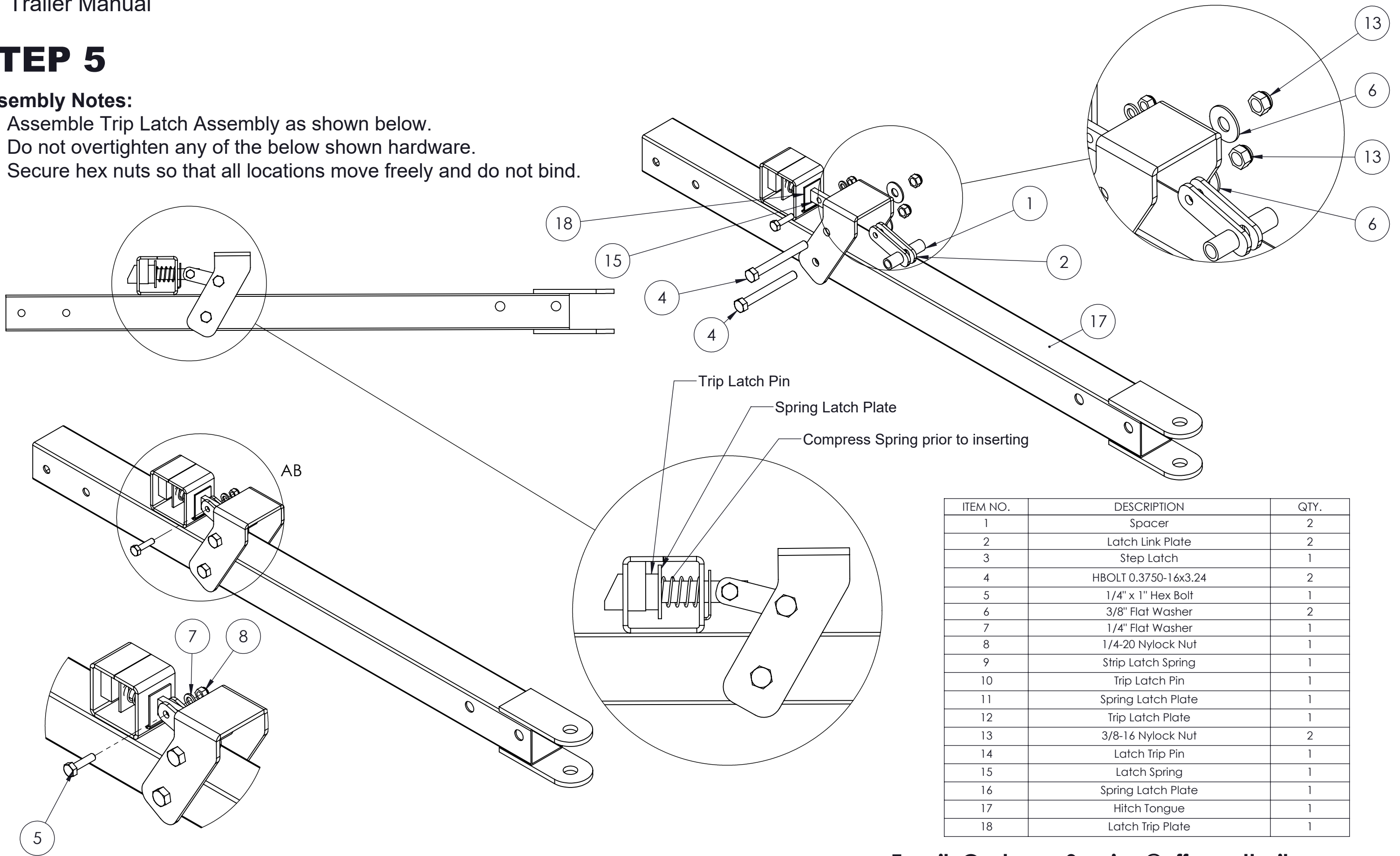

ITEM NO.	DESCRIPTION	QTY.
1	Spacer	2
2	Latch Link Plate	2
3	Step Latch	1
4	HBOLT 0.3750-16x3.24	2
5	1/4" x 1" Hex Bolt	1
6	3/8" Flat Washer	2
7	1/4" Flat Washer	1
8	1/4-20 Nylock Nut	1
9	Strip Latch Spring	1
10	Trip Latch Pin	1
11	Spring Latch Plate	1
12	Trip Latch Plate	1
13	3/8-16 Nylock Nut	2
14	Latch Trip Pin	1
15	Latch Spring	1
16	Spring Latch Plate	1
17	Hitch Tongue	1
18	Latch Trip Plate	1

STEP 6

Assembly Notes:

1. Assemble Hitch Assembly and Axle Hitch Tube.
2. Use below listed hardware to secure two sections together.

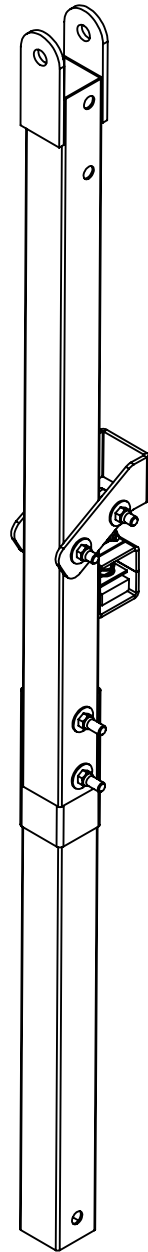
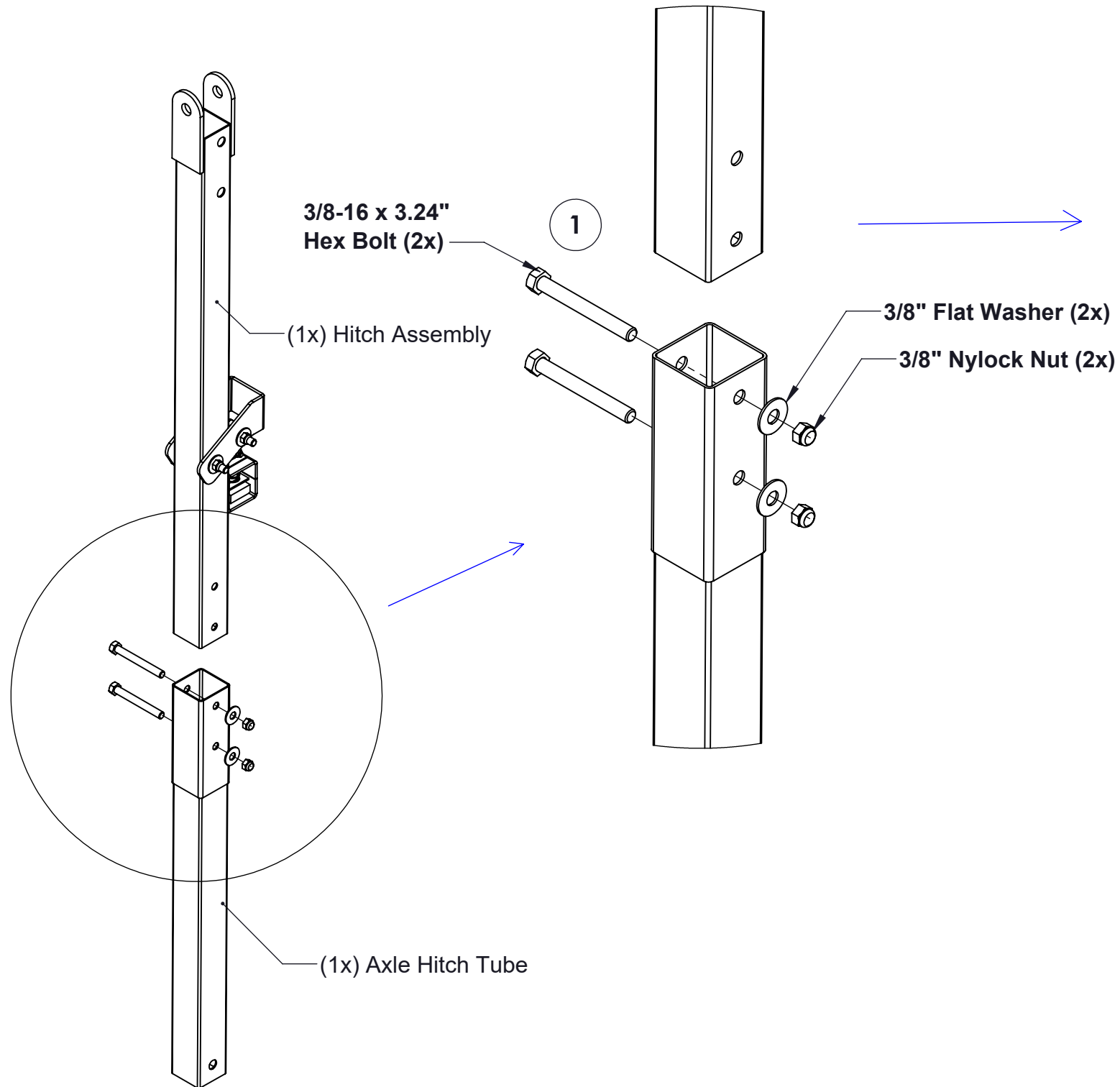

Assembly Notes:

1. Lay previously assembled trailer frame face down on floor.
2. Secure previously assembled trailer tongue assembly with below listed hardware.
3. Once assembled, tighten 1/2" Carriage Bolt and hardware so that tongue assembly will swivel freely.

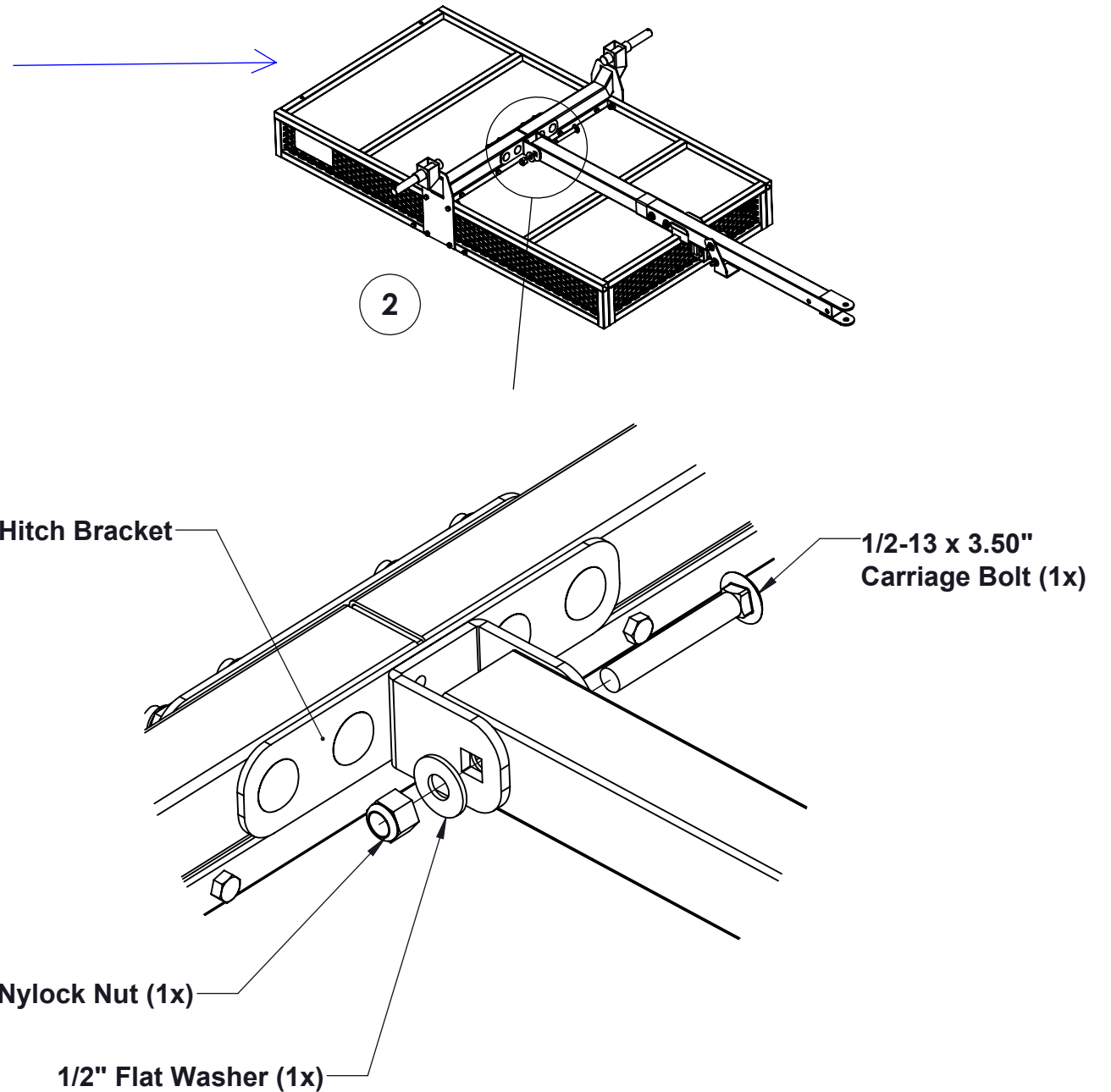

STEP 7 - XT1500

Assembly Notes:

1. Insert all Rails into main trailer upright tube fully seated to bottom.
2. Loosely Assemble all hardware as shown below.
3. Tighten all rail hardware to secure rails into upright trailer bed tubes.

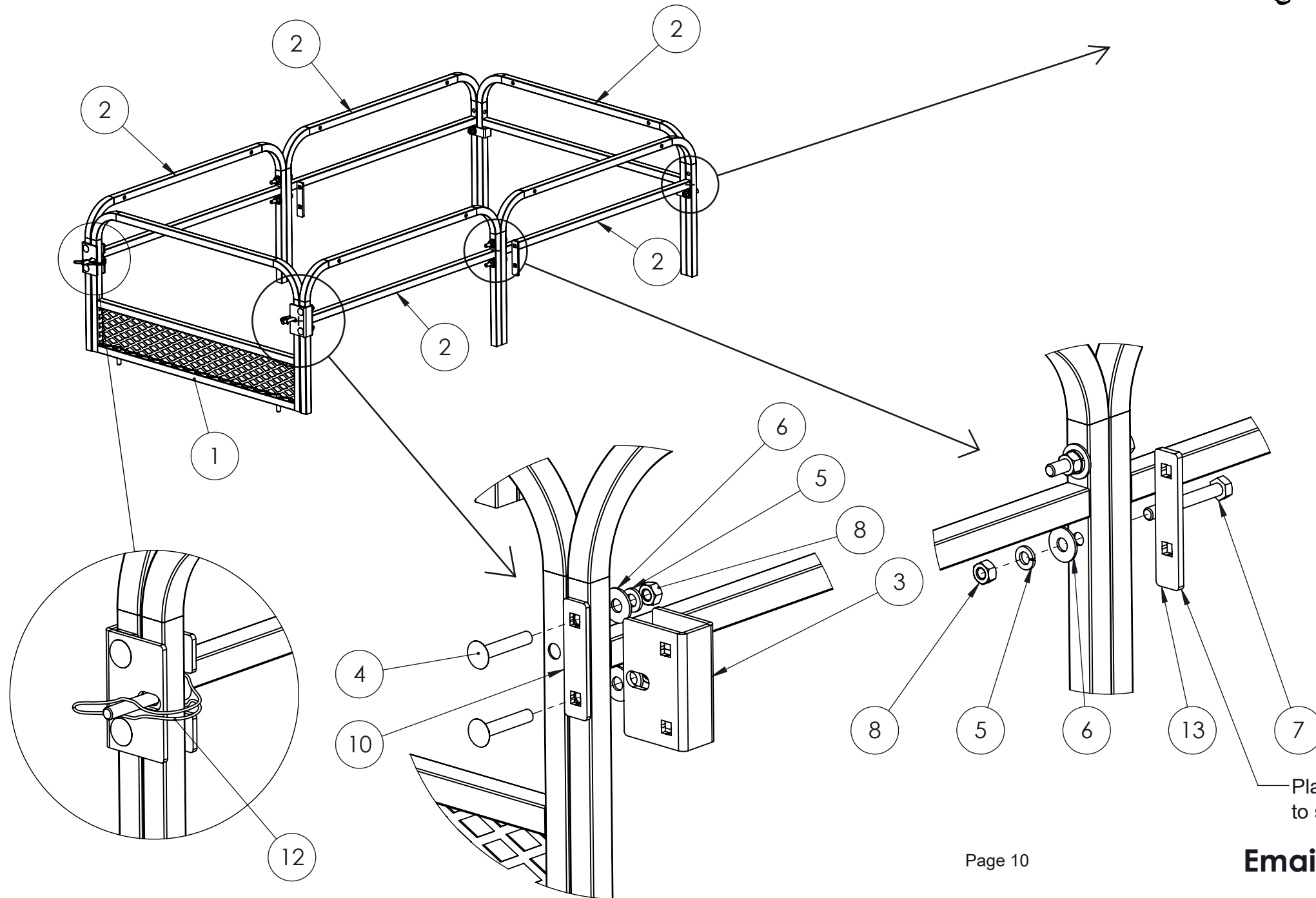
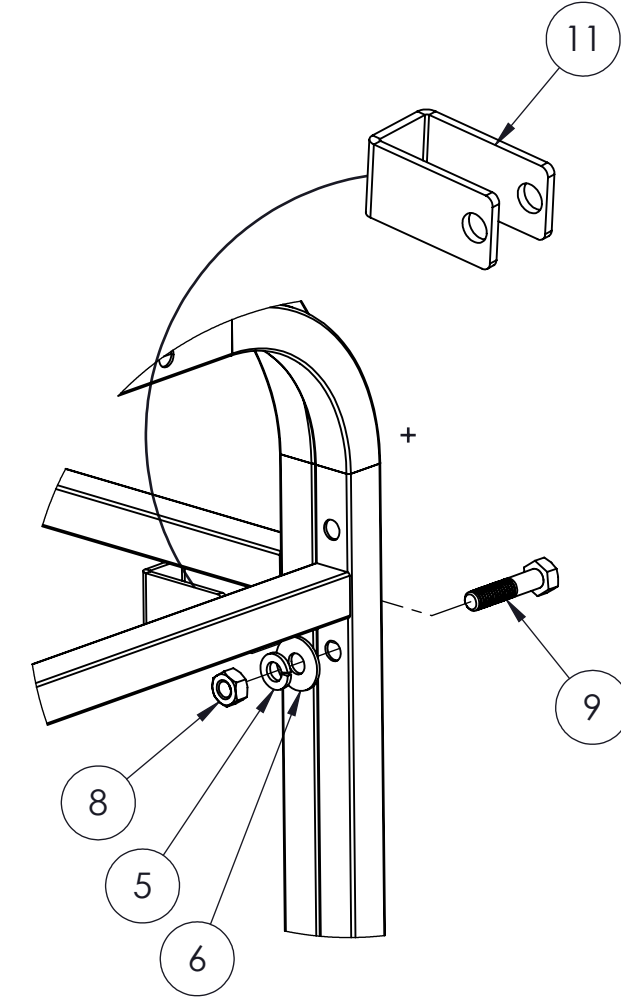
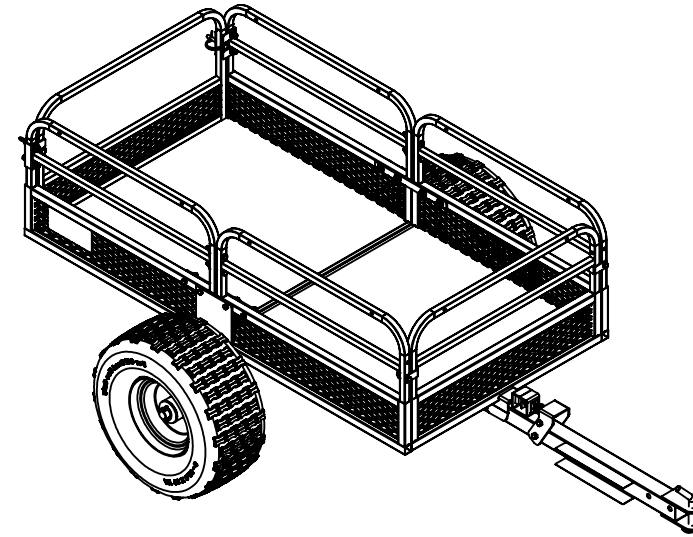

ITEM NO.	DESCRIPTION	QTY.
1	XT1500 - Rear Gate	1
2	Rail XT1500	5
3	Gate Bracket	2
4	RHSNBOLT 0.3125-18x1.75x1-N	4
5	Regular LW 0.3125	10
6	Regular FW 0.3125	10
7	HBOLT 0.3125-18x2.5x0.875-N	4
8	HNUT 0.3125-18-D-N	10
9	HBOLT 0.3125-18x1.5x0.875-S	2
10	Gate Bracket Spacer	2
11	Rail Connector 2	2
12	5/16" DIA ROUND PIN W/WIRE LOCK	2
13	Rail Spacer Plate	2

Place Rail Spacer Plate Between Rails prior to securing hardware.

STEP 7 - XT1000

Assembly Notes:

1. Insert all Rails into main trailer upright tube fully seated to bottom.
2. Loosely Assemble all hardware as shown below.
3. Tighten all rail hardware to secure rails into upright trailer bed tubes.

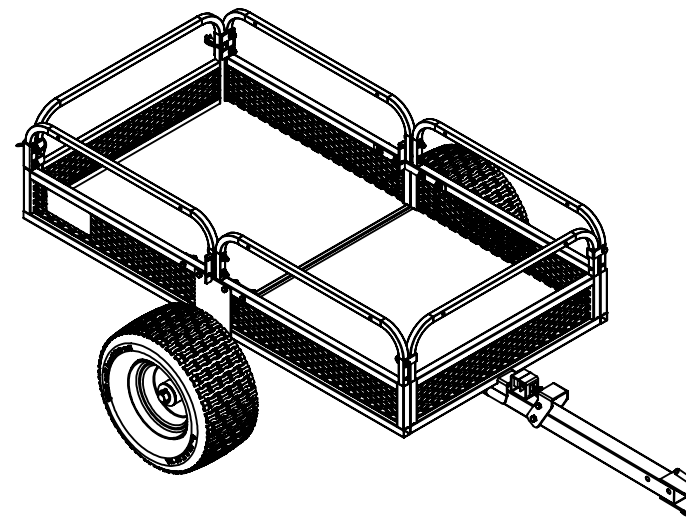

XT1000 Off-Road Trailer
Rated Capacity 1000lb

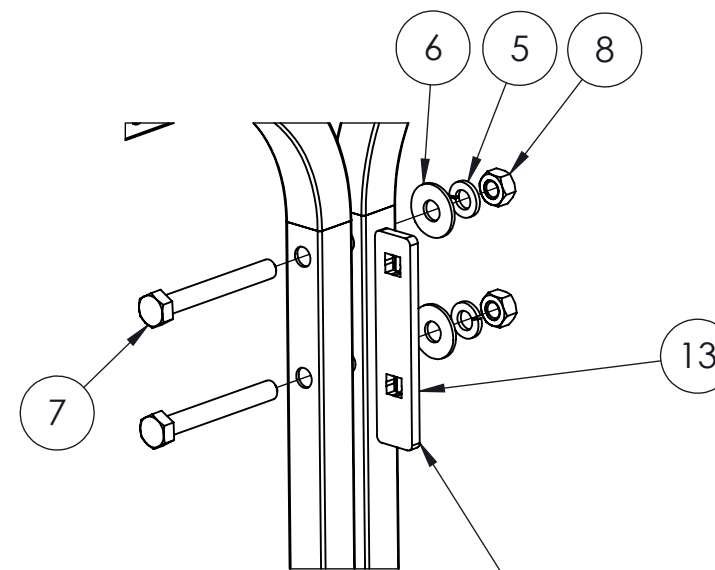
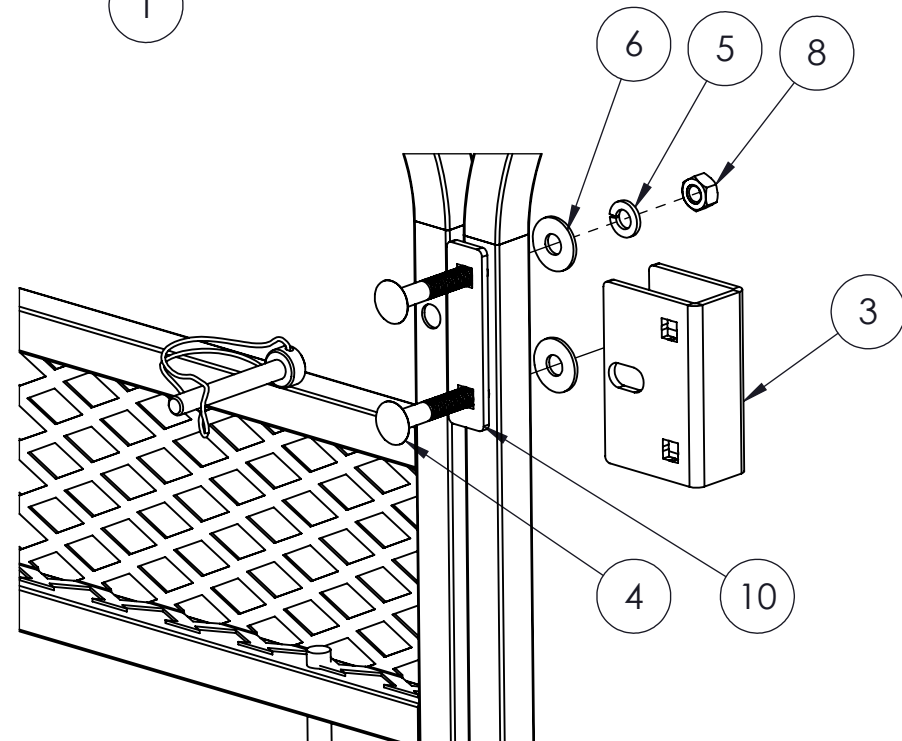
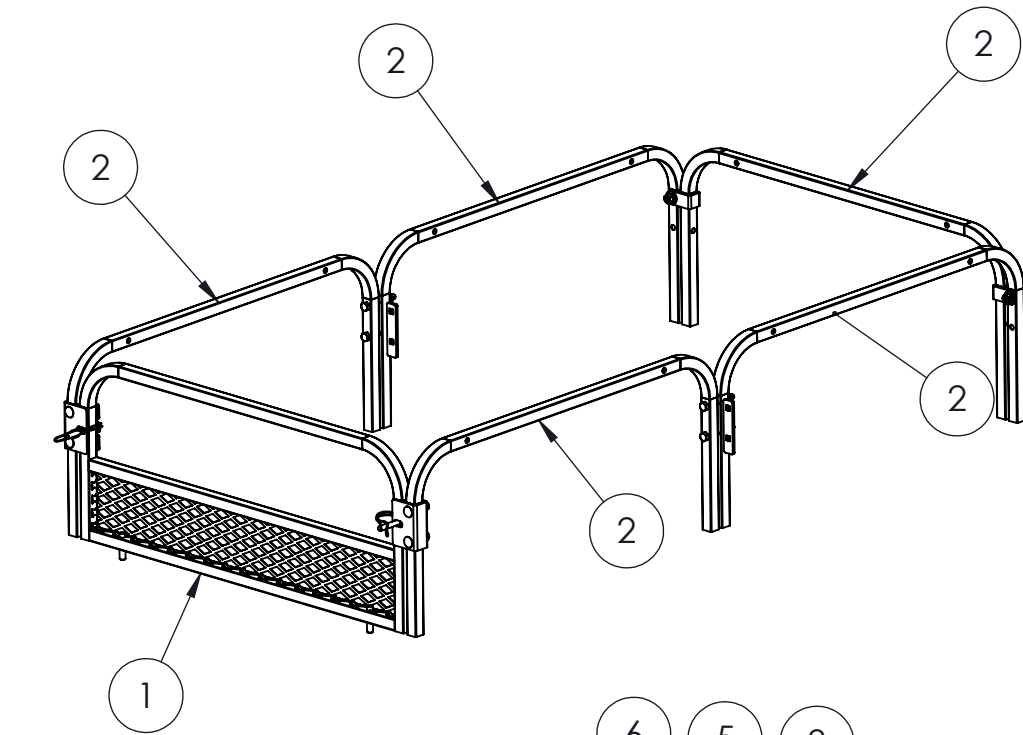
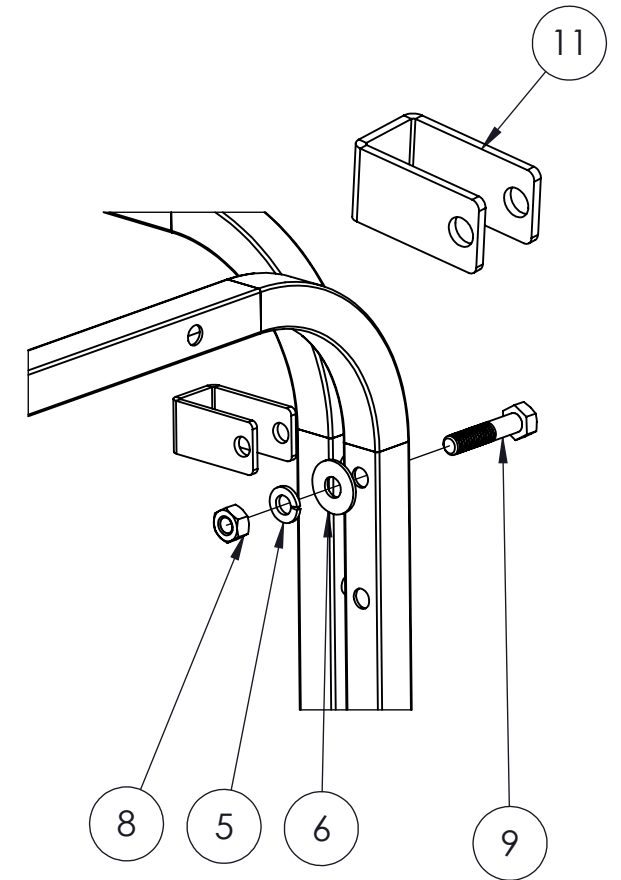

Place Rail Spacer Plate Between Rails prior to securing hardware.

Item No.	DESCRIPTION	QTY.
1	XT1000 - Rear Gate	1
2	Rail XT1000	5
3	Gate Bracket	2
4	Carriage Bolt 5/16" x 1.75"	4
5	Regular LW 0.3125	10
6	Regular FW 0.3125	10
7	HBOLT 0.3125-18x2.5x0.875-N	4
8	HNUT 0.3125-18-D-N	10
9	HBOLT 0.3125-18x1.5x0.875-S	2
10	Gate Bracket Spacer	2
11	Rail Connector 2	2
12	5/16" DIA ROUND PIN W/WIRE LOCK	2
13	Rail Spacer Plate	2

Final Step

Assembly Notes:

1. Locate (2) 1" Washers, (2) Wheels and (2) Lynch Pins.
2. Slide wheel onto end of axle with Valve Stem outward.
3. Place 1" Washer on axle then secure with Lynch Pin.

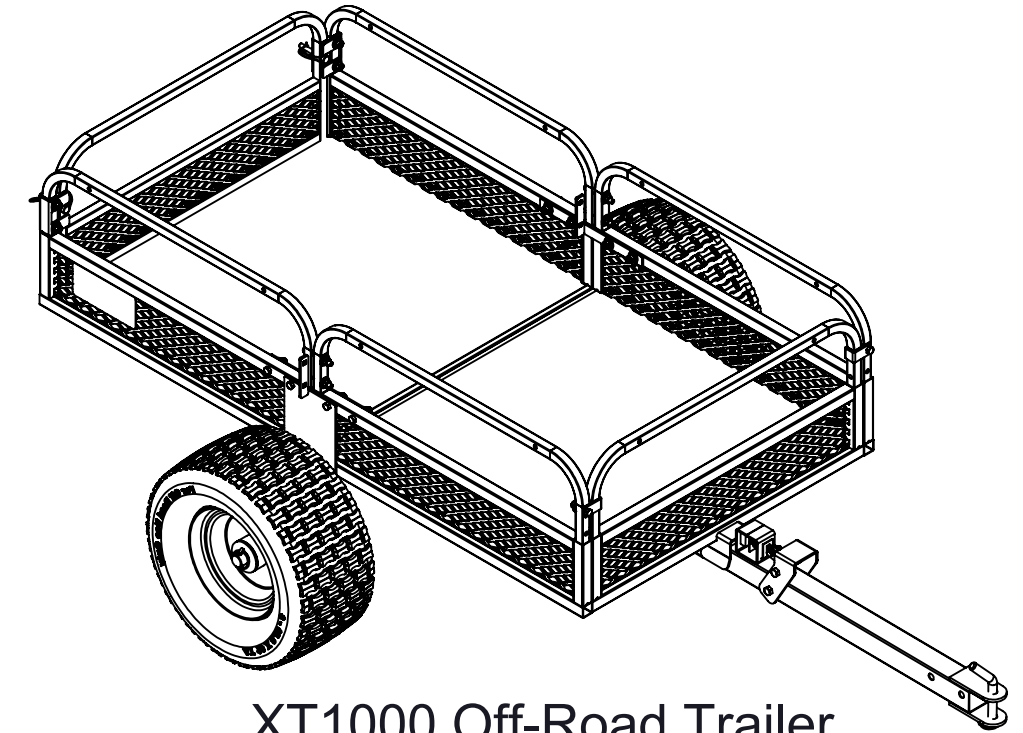

XT1000 Off-Road Trailer

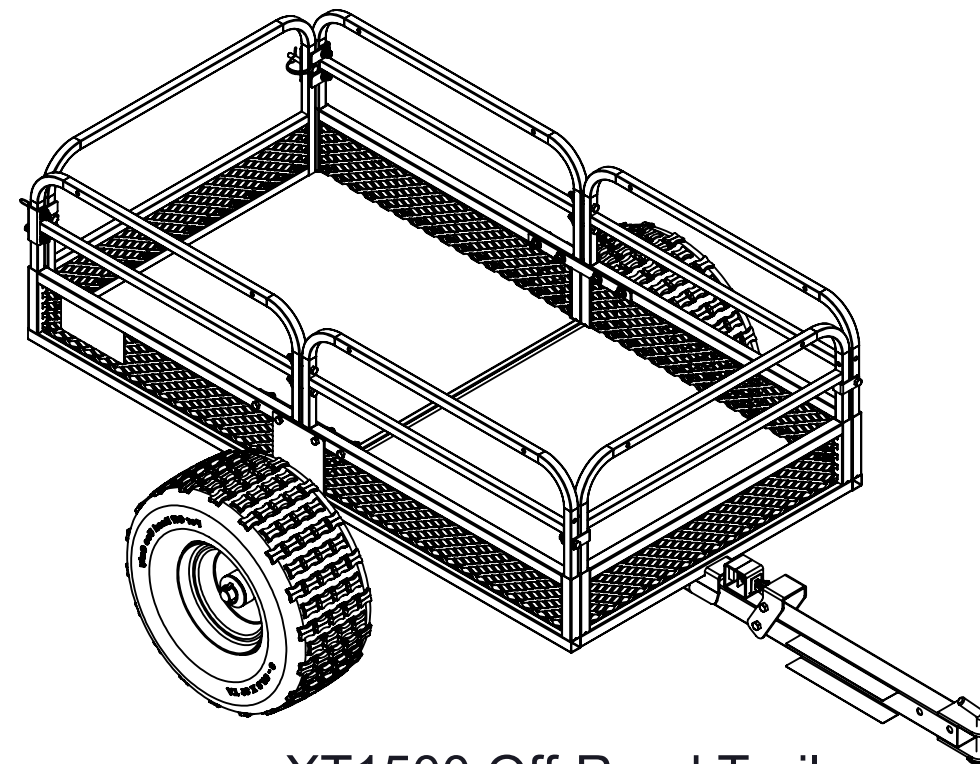
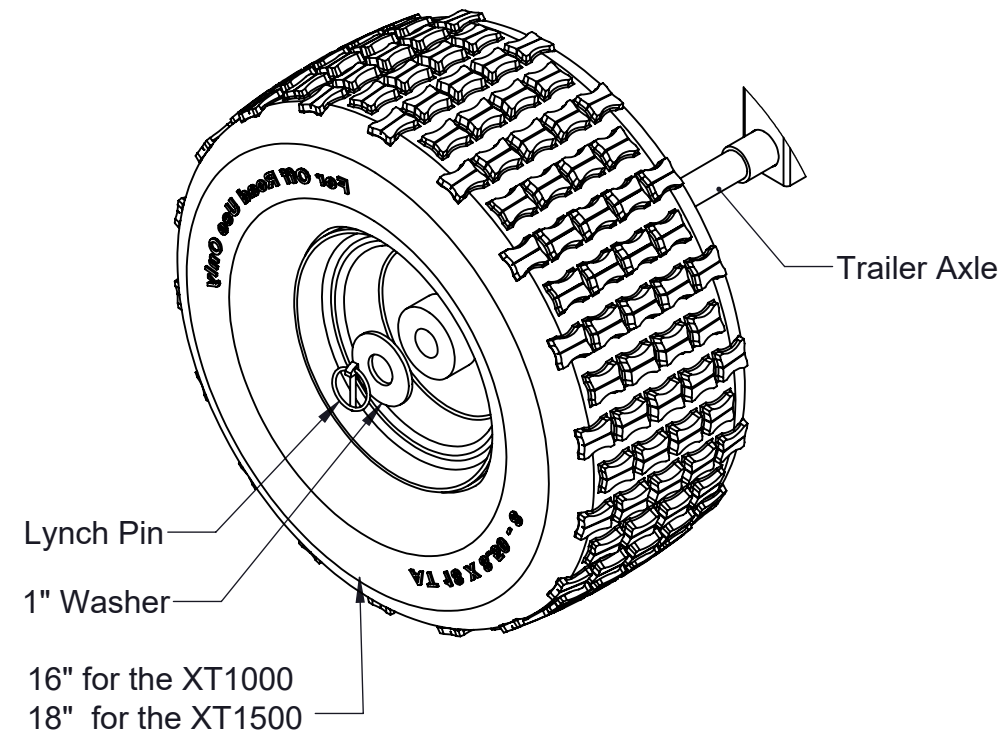

XT1500 Off-Road Trailer